

Best Practices for Using Radar in Still Pipes and Chambers



Contents

Introduction	2	Interface applications in chambers	13
Advantages of using still pipes and chambers	2	Installation guidelines for non-contacting radar	17
Which radar to use: guided wave radar or non-contacting?	3	Transmitter configuration	22
Installation guidelines for guided wave radar	4	Performance and measuring range	22
Replacing displacers with guided wave radar	8		

1.0 Introduction

This document provides a guideline for choosing and installing Rosemount™ Process radar devices in still pipes and chambers.

Even though process radars generally provide robust operation installed in still pipes, all process radars regardless of make or type are designed to perform at their very best during free propagation. Installed in still pipes, the process radar's accuracy may be affected due to the microwave propagation through the still pipe. For highest accuracy in still pipes, we have developed the Rosemount 5900 Radar Level Gauge with unique array antennas utilizing a low-loss microwave mode dedicated for still pipes. Refer to Rosemount 5900S Radar Level Gauge [Product Data Sheet](#) and Rosemount 5900C Radar Level Gauge [Product Data Sheet](#) for more information.

Chambers — also known as bypass chambers, bridles, side-pipes, bypass pipes, and cages — are used to obtain a level or interface measurement from the outside of a process vessel.

Still pipes and chambers are used in many applications and many different types of tanks and vessels. The two installation methods will jointly be referred to as pipes. Radar transmitters can be used in these installations, but function differently in pipes than in normal vessel installations. This guide is intended to assist with radar device selection and installation for optimal performance.

Figure 1-1. Example of a chamber (left) and a still pipe (right)

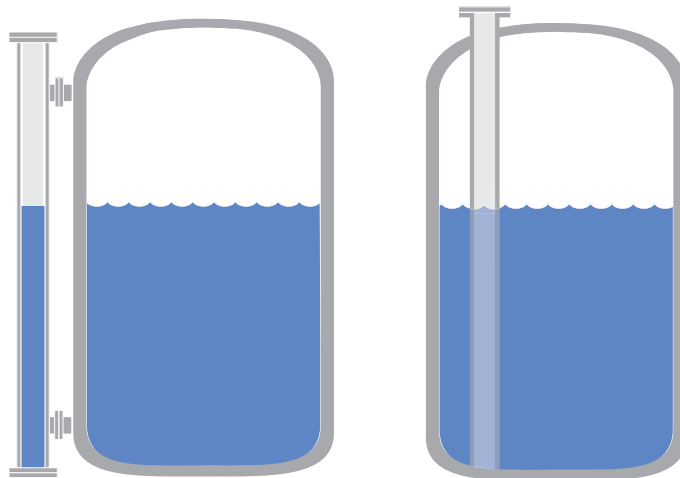

2.0 Advantages of using still pipes and chambers

The benefit of using a still pipe/chamber will differ depending on the application. The following are some typical examples.

2.1 Still pipes and chambers create calmer and cleaner liquid surfaces

A pipe can increase the reliability and robustness of the level measurement, especially for non-contacting radar (NCR).

It should be noted that the coaxial probe of a Guided Wave Radar (GWR) is essentially a probe within a small still pipe. It should be considered as an alternative to still pipes for clean fluid applications.

2.2 Still pipes and chambers eliminate issues with disturbing obstacles

Pipes isolate the transmitter from disturbances such as other pipes, agitation, fluid flow, foam, and other objects. The pipes can be located anywhere in the vessel that allows access. For GWR, the microwave signals are guided by the probe, making it more resistant to disturbing objects.

2.3 Chambers provide access to specific areas of interest

Chambers are mounted on the outside of a vessel using ports to allow liquid to move freely between the chamber and the vessel. Some applications may only require the chamber to be mounted on a small section of the vessel or column. For example, if you had an oil tank and were expecting only some water in the tank, you would perhaps use a chamber only on the lower portion of the tank or vessel or maybe you are measuring tray level in a distillation column.

2.4 Chambers allow instrumentation to be isolated from a vessel

A chamber housing a radar probe can increase the reliability and robustness of the level measurement. Because the liquid in a chamber has passed through a port, there will not be the same amount of agitation, turbulence, or foam in a chamber. Additionally, a metal chamber acts as a shield and amplifier to the radar signal, giving more reliable reflections in low dielectric liquids and allowing you to avoid metal objects that are located directly in the tank or vessel. This prevents these elements from affecting the reliability and accuracy of the measurement.

Chambers often include valves on the connection ports to allow instrumentation isolation for verification or removal for servicing. Chambers are not without limitations, however. Generally, chambers should be used with cleaner fluids that are less likely to leave deposits and with fluids that are not viscous or adhesive. Apart from the additional cost of installation, there are some probe sizing and selection criteria that must also be considered. This document outlines those considerations.

3.0 Which radar to use: guided wave radar or non-contacting?

Although NCR works well in pipe applications, contacting or GWR may be a simpler choice. NCR must meet certain installation requirements for optimum results. The GWR has simpler installation requirements and provides better performance than NCR. GWR can maintain its accuracy and sensitivity independently of the pipe.

GWR is the preferred technology for shorter installations, which makes it a suitable replacement for caged displacers. See [“Replacing displacers with guided wave radar” on page 8](#) for more details. Also refer to the [Replacing Displacers with Guided Wave Radar Technical Note](#). The probes are available in a variety of materials to handle corrosive fluids.

Taller pipes have higher tendency of being crooked, which increases the risk of GWR probes coming into contact with the pipe wall. Therefore, in tall pipes with small diameter NCR may be advantageous. It is also the preferred technology for applications with heavy deposition or very sticky and viscous fluids or where ball valves restrict the use of GWR.

4.0 Installation guidelines for guided wave radar

4.1 GWR in chambers: what probe to use?

The large diameter coaxial probe should always be considered first whenever the application and dimensions of the chamber allow for it. Large diameter coaxial probes offer the strongest return signal and have no upper dead zone and a very small lower dead zone, making them a suitable option for installation in chambers with limited space above and below the process connections. This type of probe has the best interface resolution, with a capability of detecting interface layers down to 1 in. (25 mm) and outstanding performance with low dielectric fluids. It is also completely unaffected by external disturbances such as protruding welds and side taps.

Rigid probes are a suitable option for chamber installations. When used in a metal, small diameter pipe, single rigid probes offer a stronger return signal than when used in open applications. This makes them suitable for low dielectric and interface applications. Flexible probes may be used in longer chambers, but care must be taken to ensure that the probe is suspended in a true vertical position and does not touch the pipe wall. If flexible probes are to be used, the chambers should be 4 in. (100 mm) or larger in diameter to allow room for some flexing. Also, as fluid moves into the pipe, it may push the probe toward the pipe wall. If the probe touches the wall, false reflections will create false level measurements. Coaxial probes are unaffected by these issues and rigid probes are less susceptible to them. Flexible probes simply need more room. Very narrow chambers allow little room for movement or flexing of the probe.

4.2 Centering discs

To prevent the probe from contacting the chamber wall, centering discs are available for rigid and flexible probes. Centering discs are not needed when using a large coaxial probe or a standard coaxial probe. For rigid single probes it is usually sufficient to fit one centering disc at the probe end, while flexible single probes may require several centering discs installed at points down the probe to keep it centered and prevent it from touching the chamber wall. It is recommended to use a maximum of five centering discs for each probe. The space between each disc must be at least 3 ft. (1 m).

When using a metallic centering disc at the probe end, the lower transition zone is 8 in. (20 cm), including a weight if applicable. When using a PTFE centering disc at the probe end, the lower transition zone is not affected. The lower transition zone is also not affected by PEEK snap-on centering discs installed along the probe.

4.3 Flushing connections and vents

For submerged single probe applications, it is desirable to vent the chamber near the top. This will ensure there is no trapped air or gas, which can affect the reading for the level of the liquid. A large coaxial probe set to level and interface mode is insensitive to an air gap, so venting is not required unless it is desirable to read the level all the way up to the flange. Venting is also needed if the level in the chamber will be manipulated to verify the output of the GWR or to drain the chamber. The following options will accomplish this task:

- A separate flushing ring may be inserted between the GWR flange and the chambers that use ASME or DIN flanges.
- Proprietary flanges are available with an integrated vent option. They are used with 1½ NPT threaded probes.

4.4 Chamber requirements

Probes of different styles and materials are available for use with Rosemount GWR. Table 1-1 shows the various options and appropriate pipe sizes and lengths. GWR may be used in chambers made of metal, plastic, and other non-metallic materials. All chambers provide isolation from the process conditions. Metallic chambers help to increase signal strength and shield the probe from EMI disturbances. If EMI is present and a non-metallic pipe must be used, a Rosemount 5300 Guided Wave Radar Level Transmitter with a large diameter coaxial probe should be used although a standard coaxial can also be considered for clean applications.

Table 1-1. Probe Styles and Installation Considerations

	Large coaxial	Single rigid	Single flex	Coaxial
Maximum recommended length of chamber	19 ft. (6 m)	10 ft. (3m)	33 ft. (10 m)	19 ft. (6 m)
Centering disc	N/A	Yes	Yes	N/A
Recommended chamber diameter	3 in. (80 mm) or 4 in. (100 mm)	3 in. (80 mm) or 4 in. (100 mm)	4 in. (100 mm)	3 in. (80 mm) or 4 in. (100 mm)
Minimum dielectric Rosemount 5300	1.2 (STD) 1.4 (HP)	1.25 (STD) 1.4 (HP) 1.4 (HTHP)	1.4 (STD) 1.6 (HP) 1.6 (HTHP)	1.2 (STD) 1.4 (HP) 2.0 (HTHP)
Minimum chamber diameter	2 in. (50 mm)	2 in. (50 mm)	Consult factory	2 in. (50 mm)

Table 1-2. Rosemount 5300: Blind Zones Vary with Probe Type

Probe type	Upper Blind Zone		Lower Blind Zone	
	High dielectric	Low dielectric	High dielectric	Low dielectric
Large coaxial	0 in. (0 cm)	0 in. (0 cm)	0.8 in. (2 cm)	2.0 in. (5 cm) ⁽¹⁾ 4.3 in. (11 cm) ⁽²⁾
Single rigid	4 in. (10 cm)	3.5 in. (9 cm)	0.4 in. (1 cm)	4.7 in. (12 cm)
Single flex	4 in. (10 cm)	3.5 in. (9 cm)	0.4 in. (1 cm)	4.7 in. (12 cm)
Coaxial	2 in. (5 cm)	3.5 in. (9 cm)	0.8 in. (2 cm)	5.1 in. (13 cm)

1. Liquid product level and interface level measurement mode.

2. Liquid product level measurement mode.

Table 1-3. Rosemount 3308: Blind Zones Vary with Probe Type

Probe type	Upper Blind Zone		Lower Blind Zone	
	High dielectric	Low dielectric	High dielectric	Low dielectric
Single rigid	3.2 in. (8 cm)	4.3 in. (11 cm)	5.1 in. (13 cm)	4.3 in. (11 cm)
Single flex	3.2 in. (8 cm)	4.3 in. (11 cm)	5.1 in. (13 cm)	4.3 in. (11 cm)
Coaxial	6.3 in. (16 cm)	5.9 in. (15 cm)	0 in. (0 cm)	3.2 in. (8 cm)

Table 1-4. Centering Disc Dimensions

Disc size	Actual disc diameter
2 in.	1.8 in. (45 mm)
3 in.	2.7 in. (68 mm)
4 in.	3.6 in. (92 mm)
6 in.	5.55 in. (141 mm)
8 in.	7.40 in. (188 mm)

Table 1-5. Centering Disc Size Recommendation for Different Pipe Schedules

Pipe size	Pipe schedule					
	5s, 5	10s, 10	40s, 40	80s, 80	120s, 120	160s, 160
2 in.	2 in.	2 in.	2 in.	2 in.	N/A ⁽¹⁾	N/A ⁽²⁾
3 in.	3 in.	3 in.	3 in.	3 in.	N/A ⁽¹⁾	2 in.
4 in.	4 in.	4 in.	4 in.	4 in.	3 in.	3 in.
5 in.	4 in.	4 in.	4 in.	4 in.	4 in.	4 in.
6 in.	6 in.	6 in.	6 in.	6 in.	4 in.	4 in.
7 in.	N/A ⁽¹⁾	N/A ⁽¹⁾	5 in.	6 in.	N/A ⁽¹⁾	N/A ⁽¹⁾
8 in.	8 in.	8 in.	8 in.	8 in.	6 in.	6 in.

1. Schedule is not available for pipe size.
2. No centering disc is available.

Figure 1-2. Weight Dimensions

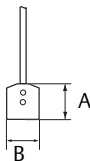
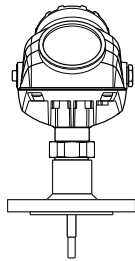

Short weight:

- A. 2 in. (50 mm); 4 mm SST probes
- B. 1.5 in. (37.5 mm); 4 mm SST probes

Long weight:

- A. 5.5 in. (140 mm); 4 mm SST probes
- B. 1.5 in. (37.5 mm); 4 mm SST probes

Table 1-6. Installation Parameters and Chamber Size Summary

Installation parameter	Chamber diameter		
	2 in.	3 in.	4 in.
Large coaxial probe	✓	✓	✓
Rigid probe	✓	✓	✓
Flexible probe	Not recommended	Application dependent	✓
Coaxial probe	✓ ⁽¹⁾	✓ ⁽¹⁾	✓ ⁽¹⁾
Side connections, large (2 in.)	Not recommended	Application dependent	✓
Side connections, small (1 in.)	✓	✓	✓
Overall length (<2 m)	✓	✓	✓
Overall length (>2 m)	Application dependent (use centering disc/heavy weight)	Application dependent (use centering disc/heavy weight)	✓
Low DC fluid (down to 1.4)	✓	✓	✓
High DC fluid	✓	✓	✓
Rapid fill rates	Application dependent	✓	✓
Boiling, turbulence	Application dependent	✓	✓
Gas lift	Application dependent	✓	✓
Viscous, clogging fluids	Application dependent, heat trace	Heat trace	Heat trace

1. Application dependent based on coating properties of the liquid.

4.5 Still pipe requirements

Pipes should be an all-metal material. Plastic, acrylic glass, or other non-metal materials do not shield the radar from outside disturbances and offer minimal, if any, application benefit. Other requirements include:

- Pipe should have a constant inside diameter.
- Pipe must be smooth on the inside (smooth pipe joints are acceptable, but may reduce accuracy).
- Avoid deposits, rust, and gaps.
- One hole above the product surface.
- Minimum hole diameter is 0.25 in. (6 mm).
- The hole diameter should be less than half of the diameter of the pipe, or maximum 4 in. (100 mm)⁽¹⁾. For example, a 4-in. pipe can have maximum 2-in. holes, and a 10-in. pipe can have maximum 4-in. holes.
- Slots should be less than 12 in. (300 mm) long and 1.5 in. (40 mm) wide.⁽¹⁾

1. If slots/holes are larger than the above recommended figures, consult your local Emerson representative.

Figure 1-3. Still Pipe Requirements

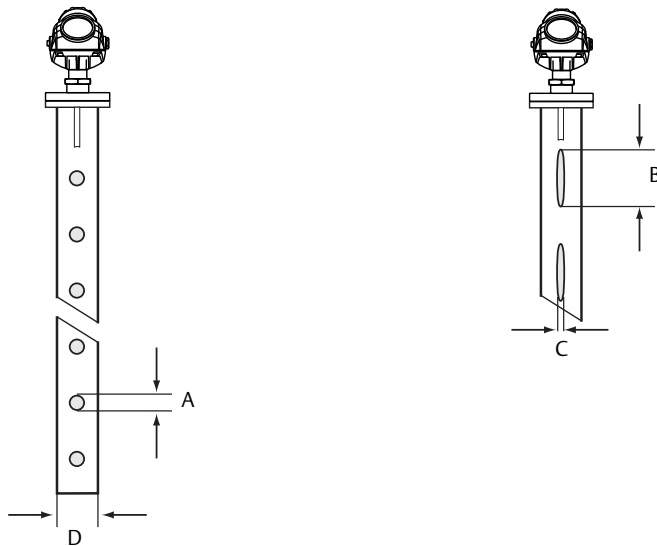

- | | |
|---|----------------------------|
| A. $\varnothing: D/2$, or maximum 4 in. (100 mm) | C. Maximum 1.5 in. (40 mm) |
| B. Maximum 12 in. (300 mm) | D. Pipe diameter |

Note

Holes/slots can be distributed around the pipe. The distance between the holes/slots does not affect the radar level measurement.

5.0 Replacing displacers with guided wave radar

5.1 Key points

- Mounting flanges vary by displacer supplier
- Probe must extend the length of the displacer chamber
- Large coaxial probe or single rigid probe are the preferred probe choices
- GWR measurements are reliable even when there is vibration or liquid density changes

5.2 Rosemount guided wave radar vs displacer

Displacers are used for level, interface, and density applications, where the buoyancy of the displacer in the fluid is the primary measurement principle. Fluid density is a key factor in determining the size of displacer required and the stability of the application, with deviation from the initial density impacting measurement accuracy. Displacers have moving parts that require frequent cleaning and replacement creating higher maintenance costs. Displacers are affected by mechanical vibration creating the potential for false readings. GWR technology has no moving parts, which means a reduction in maintenance costs as well as improved measurement accuracy and reliability. GWR is not affected by changes in density and provides reliable measurement even when there is mechanical vibration and high turbulence. Replacing displacers with GWR is simplified because existing chambers can often be used. There are many displacer flanges and styles. Both standard ASME and DIN flanges are used, as well as proprietary chamber flanges with a non-standard diameter and gasket surface. It is important to correctly match the Rosemount 5300 flange choice and probe length to the chamber.

5.3 Steps to determining replacement with the Rosemount 5300 Series

1. Determine which measurement is needed: level, interface, or density

GWR is an easy, direct replacement for displacers. For interface level measurements, the upper fluid must have a lower dielectric value than the lower fluid. See the interface guidelines below for more details. GWR is not a suitable solution for density measurements, and a differential pressure transmitter should be considered instead.

2. Check displacer chamber mounting style

Figure 1-4. Can be retrofitted with GWR

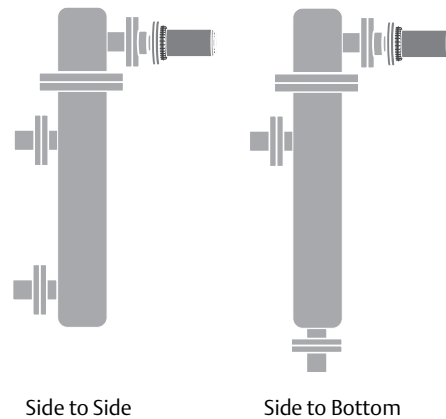
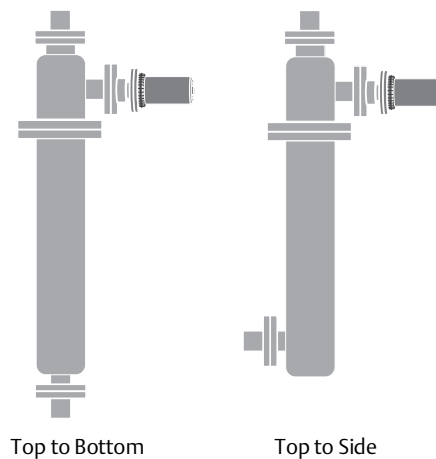

Figure 1-5. Cannot be retrofitted with GWR



3. Determine manufacturer and type of displacer chamber flange (proprietary, ASME or DIN)

The outside diameter (OD) of the flange on top of the chamber can help determine if a proprietary flange is used:

Major torque tube chambers

249B and 259B OD: 9.0 in. (229 mm)

249C OD: 5.8 in. (148 mm)

249K: 10 in. (254 mm)

249N: 10 in. (254 mm)

Masoneilan™ OD: 7.5 in. (190 mm)

All others

Per ASME or DIN specifications

4. Determine from if it is a torque tube or spring loaded displacer chamber

Figure 1-6. Spring loaded displacer chamber (left) and torque tube (right)

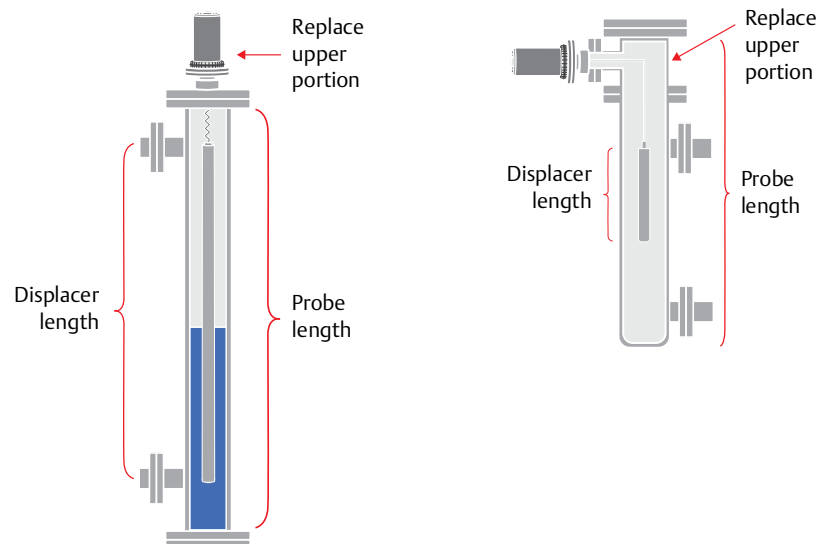

5. Determine probe length

The probe length is measured from the flange face to the bottom of the chamber (internally) as shown in Figure 1-6 or listed in Table 1-7. While the probe needs to extend the full height of the chamber, it should not touch the bottom of the chamber. There should be a small gap (between ½ to 1 in. [12 to 25 mm]) between the end of the probe and the bottom of the chamber.

Table 1-7. Chamber Manufacturers with Probe Length Corrections

Chamber manufacturer	Probe length ⁽¹⁾
Major torque-tube manufacturer (249B, 249C, 249K, 249N, 259B)	Displacer + 9 in. (229 mm)
Masoneilan (torque tube operated), proprietary flange	Displacer + 8 in. (203 mm)
Other torque tube ⁽²⁾	Displacer + 8 in. (203 mm)
Magnetrol® (spring operated) ⁽³⁾	Displacer + between 7.8 in. (195 mm) to 15 in. (383 mm)
Others — spring operated ⁽²⁾	Displacer + 19.7 in. (500 mm)

1. If flushing ring is used, add 1 in. (25 mm).
2. For other manufacturers, there are small variations. This is an approximate value, actual length should be verified.
3. Lengths vary depending in model, SG and rating, and should be verified.

5.4 Setting range values - three options

Chambers are mounted on the vessel to correspond with the desired measurement and area of control. This is often a small portion of the overall height. With displacers, the output span corresponds to the displacer length. The lower (LRV) and upper range values (URV) represent the bottom and top of the displacer. In the side-to-side chambers, this corresponds to center-of-the-pipe connections to the vessel.

Option 1 - Setting LRV to 0 in. (0 mm) at the lower tap

Set the tank height to the distance to the zero level point. In this example, it is the lower side-pipe, which is located 19 in. (483 mm) below the reference point. Output range values will equal the pipe connection heights relative to the zero level point. LRV should be set at 0 in. (0 mm) and the URV should be set at 14 in. (356 mm). The probe should be set to the correct probe length.

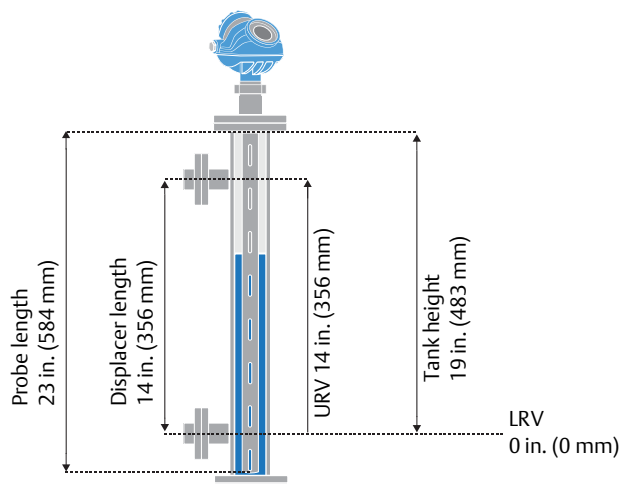

Option 2 - Matching displacer output

The tank height (reference gauge height) and the probe length should be set to the same value. The LRV is the distance from the bottom of the probe to the lower tap. The URV is the LRV plus the distance to the upper tap. In this example, tank height (reference gauge height) equals the probe length of 23 in. (584 mm), the LRV is 4 in. (102 mm), and the URV is 18 in. (457 mm).

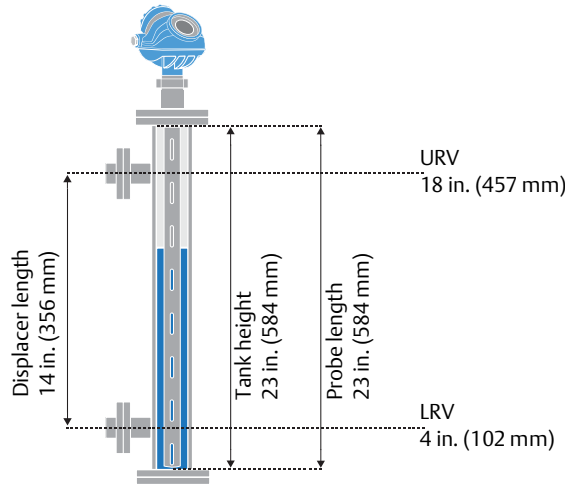

Option 3 - Matching actual tank level

For the level measurement to correspond to the actual level, the correct gauge height needs to be entered. The LRV is the distance from the bottom of the tank, or the common reference line, to the lower tank connection tap. For the URV, simply add the tank connection distance. The actual probe length needs to be entered.

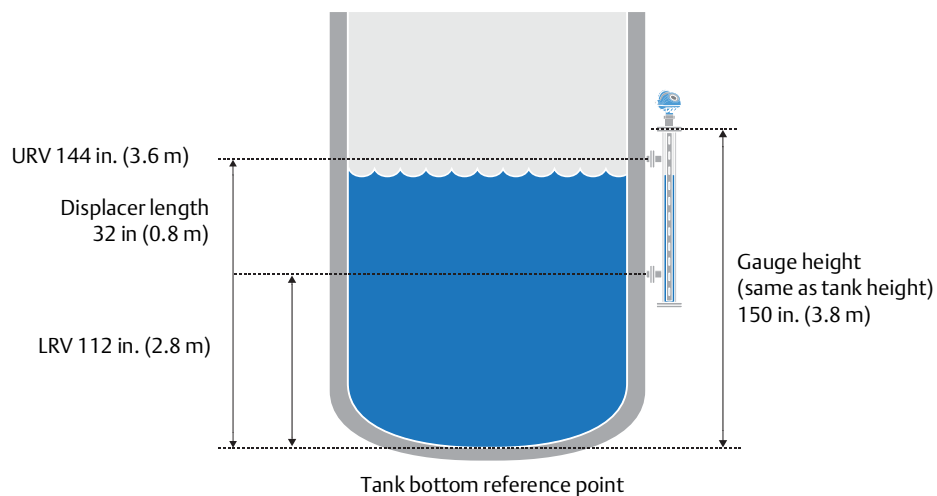

Example: Replacing a 32 in. (813 mm) displacer with a 41 in. (1041 mm) probe. The gauge height is the distance from the top flange to the tank bottom reference point. The probe length will be the actual probe length. The LRV setting will correspond to height of the lower tank connection relative to the tank bottom.

6.0 Interface applications in chambers

A large diameter coaxial probe is recommended for most chamber installations. It offers the strongest signal and is the best option for interface measurements because it will not require chamber venting. Due to the large diameter, it is less prone to build-up. An exception is for chambers where the inner diameter is <2 in., or if the liquid is highly viscous or very dirty. In these instances, single lead probes are recommended. Since the chamber walls help to amplify the signal, single probes can also be used for interface measurement and measurements of materials with a low dielectric. Centering discs are recommended whenever single lead probes are used in chambers.

6.1 Interface in chambers

The following information should be considered when measuring an interface in a chamber. The recommended practice is to measure either the level or interface. A chamber provides a fixed view of the level in a vessel. The effective measurement range of a chamber is the area between the process connections. Thus, when the level drops below or rises above those connections, it will not be visible in the chamber.

Figure 1-7. Chamber Interface Measurement Consideration

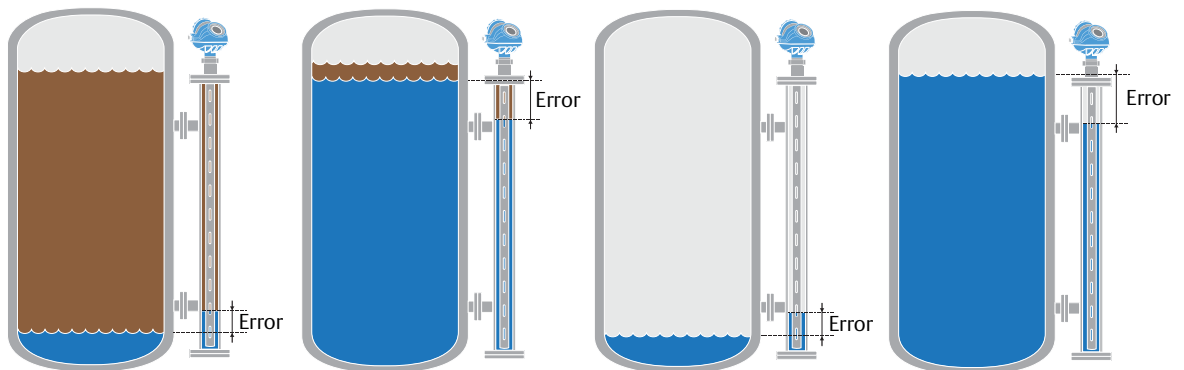

6.2 Match product in tank and chamber

Below are examples of situations that might occur in the field.

Figure 1-8. Difference in Product Specific Gravity (SG)

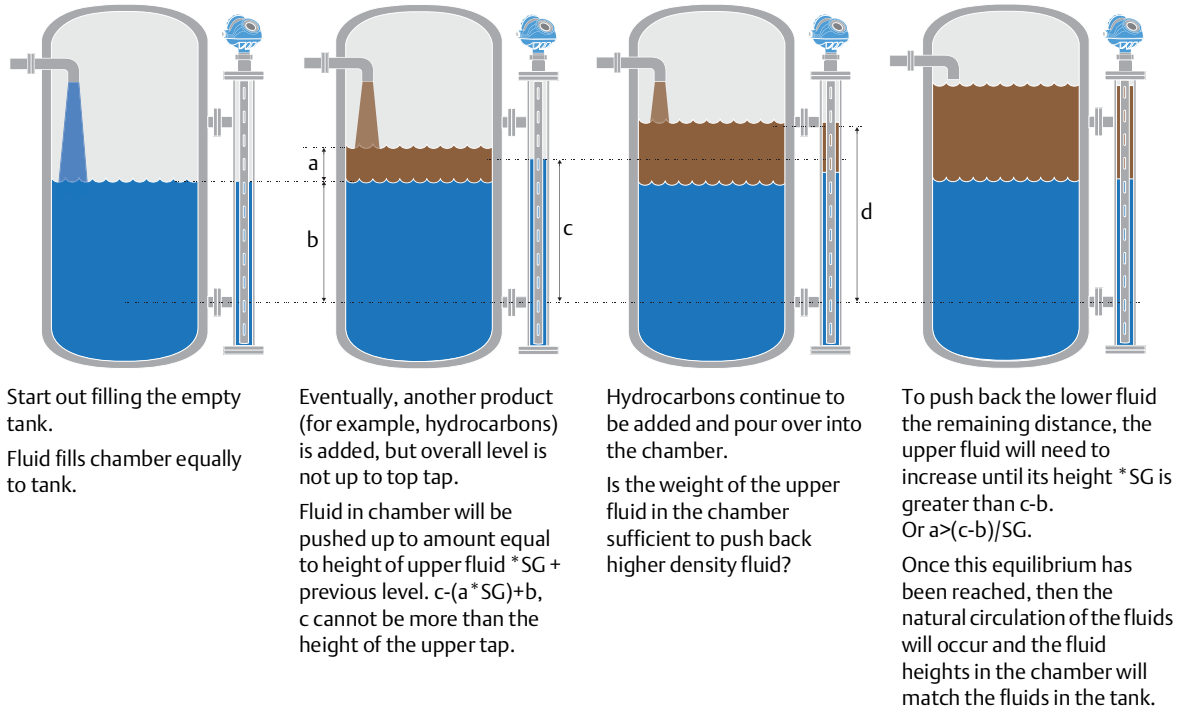
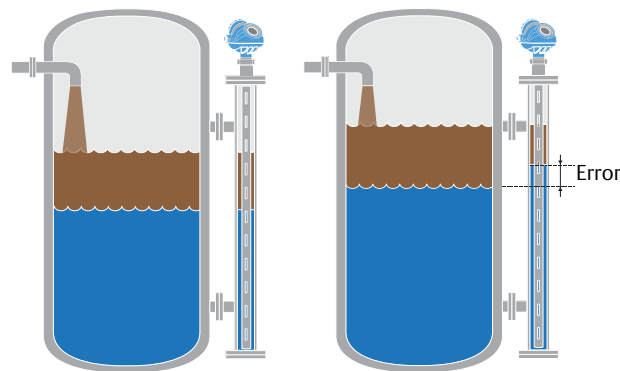

Figure 1-9. Lack of Circulation in Chamber



A finite amount of fluid is added and separation occurs.

More fluid is added in vessel, but lack of circulation in chamber prevents interface from being the same.

6.3 Submerged interface

A submerged interface application is one where the upper portion of the probe is in oil or a similar fluid and the interface between the upper fluid and lower fluid is the desired measurement. Often this measurement is performed with the probe mounted in a chamber. A Rosemount 5302 GWR with a large coaxial probe is the most appropriate solution for submerged interface applications. Even if an air pocket forms in the top of the chamber, a Rosemount 5302 with a large coaxial probe will ensure accurate measurement of both interface and level. Furthermore, in the event of power loss the transmitter will resume both level and interface measurement once power is restored.

Figure 1-10. Air Pocket Formation in a Submerged Interface Application

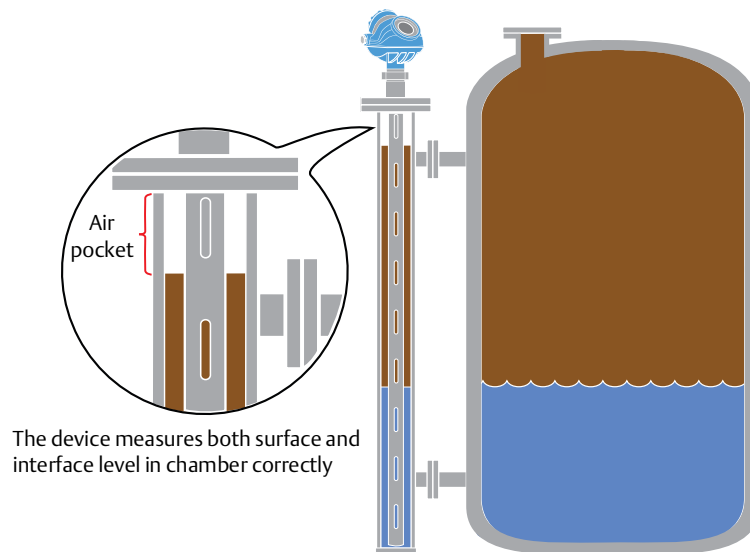

Under special circumstances, such as very viscous fluids or small chambers where the large diameter coaxial probe will not fit, a Rosemount 5301 GWR with a single rigid probe can be used to measure submerged interface. Air is often trapped in the chamber and if there is an air pocket, this creates an offset in the measurement reading due to the difference in the speed of travel of the microwaves in the air space compared to the upper fluid. For example, if the device is configured with oil as the upper fluid, with a dielectric constant of 2, the offset error will be 30 percent of the size of the air pocket (that is, a 15.7 in. (40 cm) air pocket creates a 4.7 in. (12 cm) offset error to the reading).

6.4 Level and interface measurement

Measurement of level and interface in a chamber should be avoided because the lack of fluid flow will not provide representative measurements. However, chambers are often used for interface measurements between oil and water. If this is the only way to perform a measurement, multiple connections to the chamber will help to enhance fluid flow. The additional crossover connections should be located near the most critical measurement areas.

Figure 1-11. Chamber with Multiple Connections

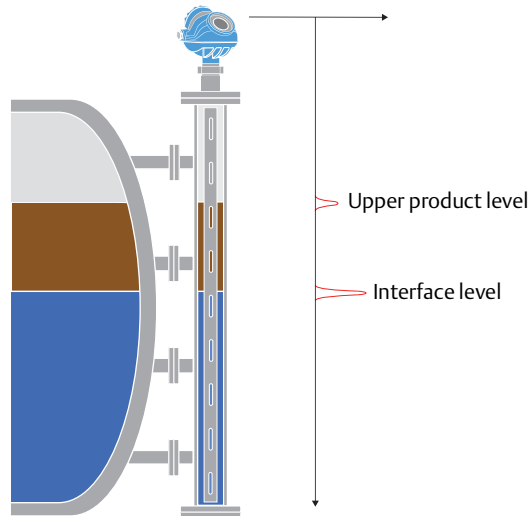

In these types of applications, for the interface measurement to be accurately measured, there must be good flow-through of both the top and bottom fluids. Care must be taken to avoid a layer of fluid being trapped in the chamber. The device must be configured to measure level and interface, with the process variable set to interface. The GWR will measure the distance to the top surface as well as the lower product. The air gap will be measured and included in the calculation of the interface level.

Level and interface measurement key points:

- Lower dielectric fluid must be on the top
- The two liquids must have a dielectric difference of at least 6
- The upper layer dielectric must be known (in-field determination is possible)
- The upper fluid layer thickness must be at least 1 in. (2.5 cm) for the Rosemount 5300 Series with a large coaxial probe
- Target applications: low upper layer dielectric (<3), high lower layer dielectric (>20)
- Dielectrics of oil and gasoline range from 1.8 to 4. Water and water-based acids have high dielectrics (>50).

7.0 Installation guidelines for non-contacting radar

7.1 Using non-contacting radar in still pipes and chambers

When radar transmitters are used in metallic pipes, the microwave signal is guided and contained within the pipe. This restriction of the signal results in a stronger signal on the surface which can be an advantage for low dielectric and/or turbulent applications. NCR can be advantageous over longer distances especially when the use of GWR is not convenient.

7.2 The impact of frequency

When radar is used inside the pipe, more than one microwave mode is generated and each mode has a unique propagation speed. The number of microwave modes that are generated varies with the frequency of the radar signal and the pipe diameter. Emerson recommends using a 2- or 3-in. pipe to minimize the number of undesired microwave modes.

7.3 General installation guidelines and choosing the right antenna

The Rosemount 5408 Non-Contacting Level Transmitter offers a wide range of antennas, including cone antennas, process seal antennas, and parabolic antenna. Of these, the cone antennas and process seal antennas are for level measurement in pipes. All cone antennas are available in SST, Alloy C-276, and Alloy 400. The process seal antennas are available with all-PTFE wetted parts.

With any radar unit, the antenna should match the pipe size as closely as possible. The cone and process seal antennas are sized to fit within schedule 80 or lower and within schedule 120 or lower pipes respectively.

Table 1-8. General Pipe Installation Guidelines for Rosemount 5408

Installation parameter	Cone antenna	Process seal antenna
Maximum gap between antenna and pipe ⁽¹⁾⁽²⁾	0.2 in. (5 mm)	0.2 in. (5 mm)
Maximum antenna inclination ⁽³⁾	< 1° of vertical	< 1° of vertical
Availability per pipe size		
2 in.	✓ ⁽⁴⁾	✓ ⁽⁵⁾
3 in.	✓ ⁽⁴⁾	✓ ⁽⁵⁾
4 in.	✓ ⁽⁴⁾	Consult factory
6 in.	✓ ⁽⁶⁾⁽⁷⁾	✗
8 in.	✓ ⁽⁶⁾⁽⁷⁾	✗
Can be used with full port valve	✓	✓
Can be used in applications with heavy condensation	✓	✓

1. In difficult measurement conditions (dirty pipes, steam, echoes from inlet pipes, welds, or valves), accuracy and range will be improved with a tighter fit between pipe and antenna.

2. Refer to [Figure 1-12 on page 18](#).

3. Refer to [Figure 1-13 on page 18](#).

4. Fits schedule 80 and lower pipes.

5. Fits schedule 120 and lower pipes.

6. Applicable only to Rosemount 5408 4-in. cone antennas.

7. Reduced accuracy, refer to [Figure 1-19 on page 23](#).

Ideally, the maximum gap between the antenna and the pipe wall should be as small as possible (see [Table 1-8 on page 17](#) and [Figure 1-12 on page 18](#)). For the Rosemount 5408, gaps of up to 0.2 in. (5 mm)⁽¹⁾ are acceptable. Larger gaps may result in inaccuracies.

Figure 1-12. Maximum Gap Between Antenna and Pipe Wall

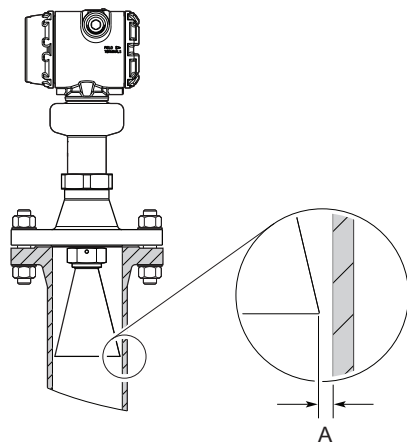

A. Maximum 0.2 in. (5 mm)

When the transmitter is mounted in a pipe, the inclination should be within 1° of vertical, as shown in [Figure 1-13](#). Even small deviations can cause large measurement errors. Also, the symmetry axis of the antenna should coincide with the center axis of the pipe to achieve a uniform gap around the antenna.

Figure 1-13. Maximum Antenna Inclination in Pipes

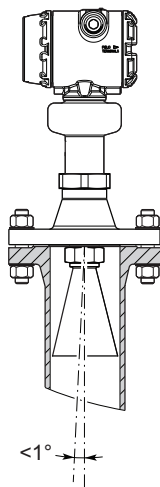

1. A larger gap is inevitable for the Rosemount 5408 with a 4-in. cone antenna in pipes with a diameter larger than 4 in. See “Performance and measuring range” on page 22.

The Rosemount 5408 transmitter heads should be oriented to minimize the impact of disturbances such as pipe inlets or still pipe holes.

Align the Rosemount 5408 transmitter head as shown in Figure 1-14.

Figure 1-14. Rosemount 5408 Transmitter Head Orientation in Still Pipe and Chamber Installations

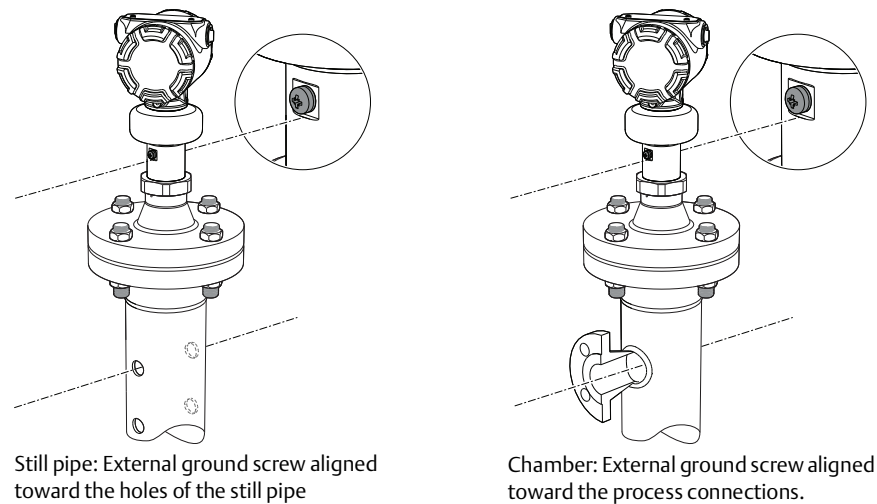

7.4 Still pipe requirement

Plastic, acrylic glass, or other non-metal materials do not shield the radar from outside disturbances and offer minimal, if any, application benefit. Due to high signal damping effect, carbon steel pipes are not suitable for non-contacting radars in pipes larger than 4 in. Other requirements include:

- Pipes should be an all-metal material.
- Pipe should have a constant inside diameter.
- The inner surface must be smooth and clear of any rough edges. (Smooth pipe joints are acceptable, but may reduce accuracy.)
- The end of the pipe must extend beyond the zero level.
- Avoid deposits, rust, gaps, and slots.
- Maximum hole diameter is 1 in. (25 mm).
- Minimum distance between holes is 6 in. (150 mm).⁽¹⁾
- Holes should be drilled on one side only and deburred.
- Drill one hole above maximum product surface.
- Ball valve or other full port valves must be completely open.
- Level will not be measured accurately below the pipe opening.
- In heavy condensation applications, insulate the pipe part/nozzle which is outside the tank atmosphere.

Failure to follow these requirements may affect the reliability of the level measurement.

1. The minimum distance between holes is not always the optimal distance. Consult factory or product documentation for best installation practices.

Figure 1-15. Still Pipe Requirements

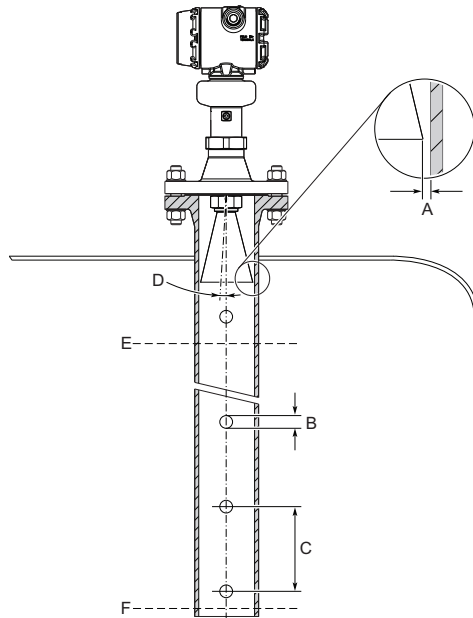

- | | |
|---------------------------|-----------------|
| A. Maximum 0.2 in. (5 mm) | D. Maximum 1° |
| B. Maximum 1 in. (25 mm) | E. Level = 100% |
| C. Minimum 6 in. (150 mm) | F. Level = 0% |

Use a deflection plate in flat bottom tanks

In flat-bottom tanks (<math><20^\circ</math> incline), where the fluid has a low dielectric and a measurement close to the bottom of the tank is desired, a deflection plate should be used. This will suppress the bottom echo and allow measurements closer to the pipe end. This is not necessary for dish- or cone-bottomed tanks where the slope is more than 20° .

Figure 1-16. Deflection Plate

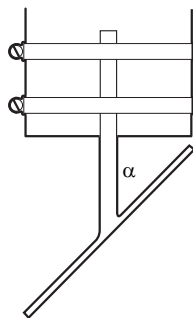

7.5 Chamber requirements

The distances between the antenna and the chamber wall and inlet pipes should meet those shown in Figure 1-17. If the inlet pipe tolerances are too restrictive, an alternative solution may be to mount a smaller pipe within the chamber, or consider using GWR.

Consider the following chamber requirements:

- Pipes should be an all-metal material.
- Pipe should have a constant inside diameter.
- Inlet pipes should not protrude into the inside of the stand pipe.
- The inner surface must be smooth and clear of any rough edges. (Smooth pipe joints are acceptable, but may reduce accuracy.)
- The gap between the cone antenna and the stand pipe should be maximum 0.2 in. (5 mm).
If required, order a larger antenna and cut on location.

Figure 1-17. Chamber Requirements

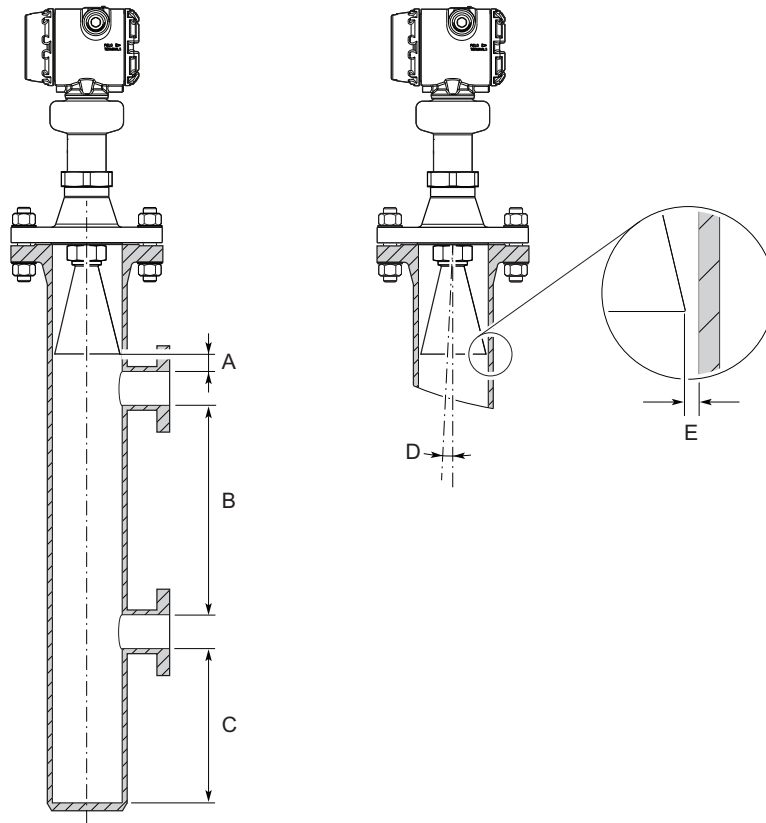

- A. Minimum 0.4 in. (10 mm)
- B. Minimum 20 in. (500 mm)
- C. Minimum 6 in. (150 mm)

- D. Maximum 1°
- E. Maximum 0.2 in. (5 mm)

8.0 Transmitter configuration

The transmitter software contains a special pipe measurement mode, which is turned on by entering the internal diameter of the pipe⁽¹⁾. This can be done using Rosemount Radar Master, Rosemount Radar Master Plus, a handheld communicator, AMS, or any other DD-compatible host-system. When this mode is turned on, the transmitter will be optimized for pipe measurements. For example, the dynamic gain curve will be adapted for pipes and the lower propagation velocity of the radar signal in the pipe will be compensated. Entering the actual pipe diameter into the transmitter is therefore crucial and must not be omitted. Compensation is more important on higher-frequency devices.

9.0 Performance and measuring range

The following figures reflect the anticipated performance for different radar devices when used in a pipe installation following the guidelines contained in this document. The values in the table assume that all the installation requirements stated above have been fulfilled and that the pipe is made per our recommendations.⁽²⁾⁽³⁾

The maximum measuring range is independent of the dielectric constant of the product. For the GWR the minimum dielectric and maximum range varies with probe type (see Table 1-1 on page 5). For Rosemount 5408 the maximum measuring range is affected by other factors than the dielectric constant of the product, such as foam and turbulence.

Key:

- Rosemount 5300 with coaxial/large coaxial probe or rigid twin leads⁽⁴⁾
- Rosemount 5300 with rigid, flexible, or segmented single lead⁽⁴⁾
- Rosemount 5408⁽⁵⁾⁽⁶⁾

Figure 1-18. 2-in. DN50, 3-in. DN80, and 4-in. DN100 Connections⁽⁷⁾

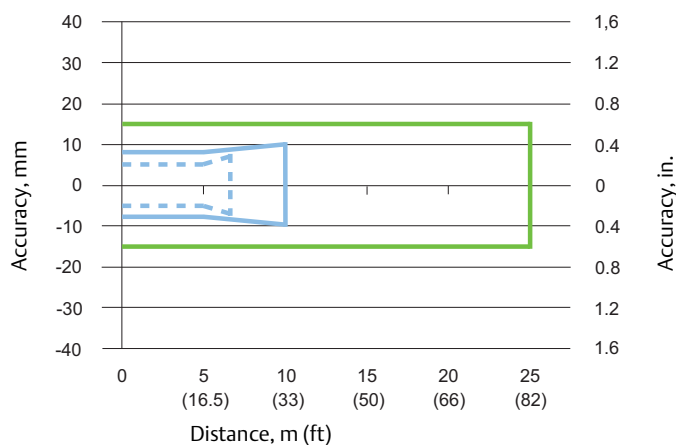

1. Accurate pipe diameter required for a proper level calculation.
2. Build-up or deposits inside the pipe may decrease the performance.
3. If the pipe inner diameter deviates, a scale factor error will appear for measurements in long pipes. For best accuracy it's recommended to perform a two-point measurement: 1. Measure with a high product level in the tank. Match the measured level value to a reference measurement and adjust the Calibration Offset parameter if necessary. 2. Measure with a low product level in the tank. Match the measured level value to a reference measurement and adjust the Pipe Inner Diameter parameter if necessary.
4. Standard probes, reference conditions.
5. Only 4-in. cone antennas for pipes larger than 4 in.
6. Consult factory for longer measuring ranges than 25 m.
7. Rosemount 5408 accuracy shown in Figure 1-18 applies to antenna sizes matching the pipe diameter.

Figure 1-19. 6-in. DN150 and 8-in. DN200 Connections

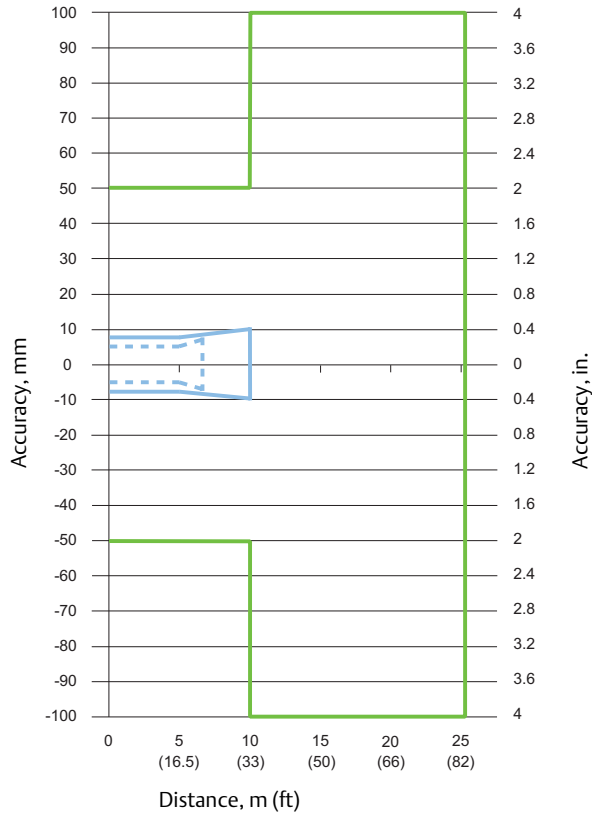

For more information: [Emerson.com](https://www.emerson.com)

© 2022 Emerson. All rights reserved.

Emerson Terms and Conditions of Sale are available upon request. The Emerson logo is a trademark and service mark of Emerson Electric Co. Rosemount is a mark of one of the Emerson family of companies. All other marks are the property of their respective owners.